



Franklin County Planning and Building Department
1016 North 4th Avenue, Pasco, WA 99301
Phone: 509-545-3521 Fax: 509-546-3367
Building Inspection Request Line: 509-545-3522

TRUSS BLOCKING

BLOCKING MUST OCCUR AT ALL THE FOLLOWING LOCATIONS:

- ALL 4' BRACED PANELS (all corners & at 25 foot intervals along wall)
- ANY ALTERNATE BRACED WALLS (will be marked on the plans)
- ALL "PORTAL FRAMES" ALONG ENTIRE LENGTH OF PORTAL FRAME
- AT ANY SPECIAL BRACING AREAS, SUCH AS 3-SIDED GARAGES (Sometimes referred to as "strong wall" design).

All other blocking between trusses can be vent blocking with 1" air space above the block for venting, or can be drilled blocking with vent holes. **Do not** end nail any blocks through the truss as damage to truss could occur.

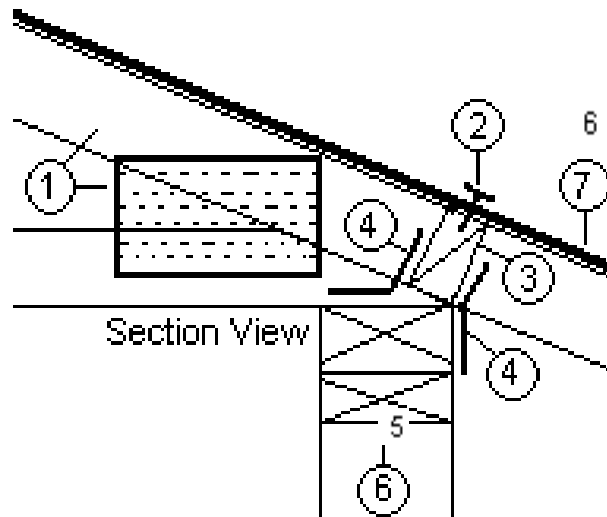

1. PRE-MFD. TRUSSES @ 24" o.c.
2. ROOF SHEATHING MUST NAIL DIRECTLY TO BLOCKING W/ 8d NAILS @ 6" o.c.
3. SOLID BLOCKING, FULL DEPTH OF SPACE; OR USE TOP-BEVELLED 2X BLOCK & TOE-NAIL TO PLATES. NO VENTS IN ANY OF THESE BLOCKS.
4. USE "SIMPSON" LS50 CLIPS, 1 PER BLOCK FRONT OR BACK SIDE OF BLOCK AS SHOWN. (TOP-BEVELLED BLOCKS CAN BE TOE-NAILED TO DOUBLE TOP PLATE).
5. DOUBLE TOP PLATES
6. ROOF SHEATHING (TYPICAL 7/16" OSB, MIN).