

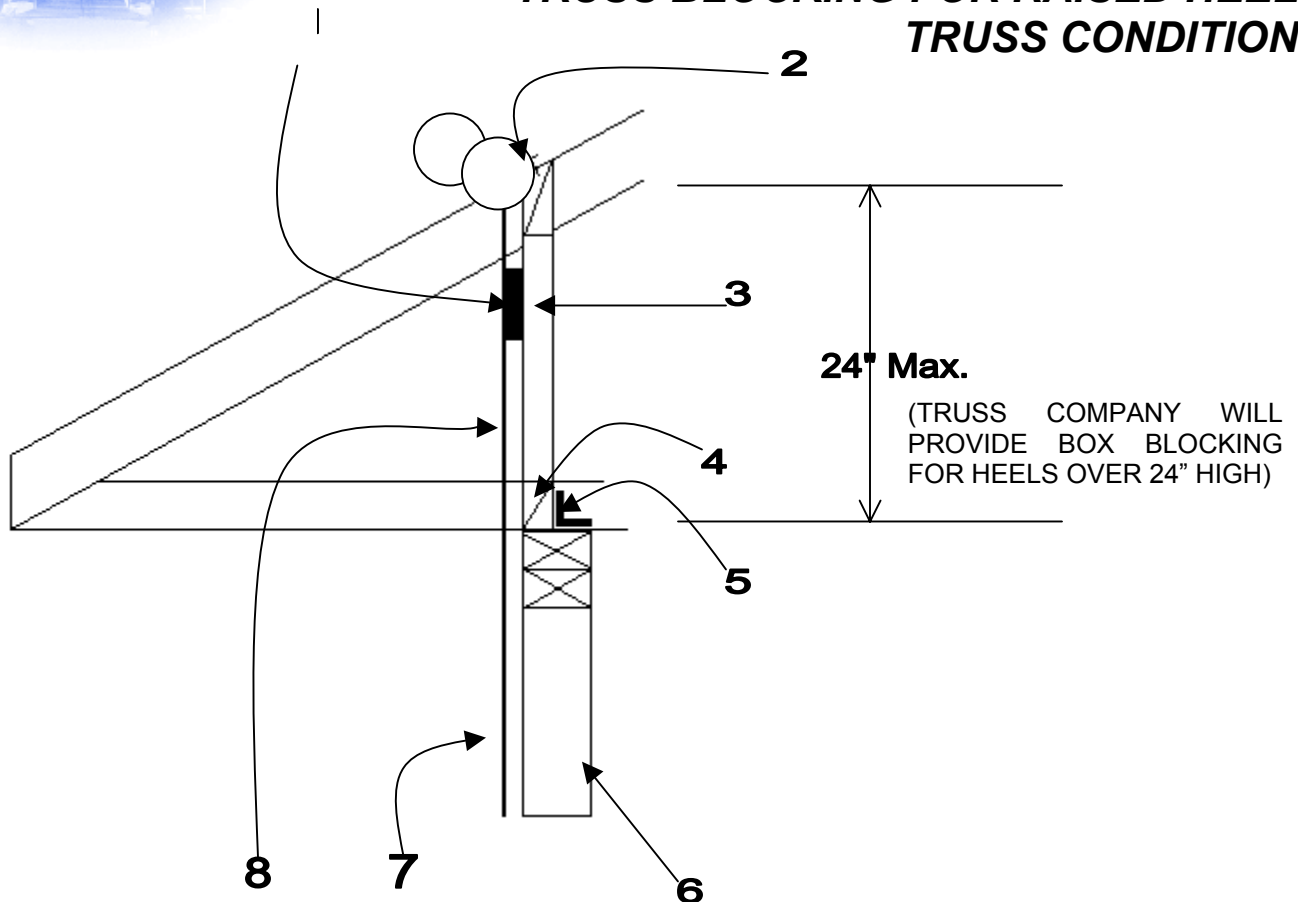

**Franklin County Planning and Building Department**  
1016 North 4<sup>th</sup> Avenue, Pasco, WA 99301  
Phone: 509-545-3521 Fax: 509-546-3367  
Building Inspection Request Line: 509-545-3522

## **TRUSS BLOCKING FOR RAISED HEEL TRUSS CONDITION**



1. (3) 2" SCREENED HOLES FOR VENTING IN EACH TRUSS SPACE
2. 2 X 4 HORIZONTAL BLOCK BETWEEN TRUSS TOP CHORDS; NAIL ROOF SHEATHING TO BLOCK 8d @ 6" ON CENTER
3. 2 X 4 VERTICALS BETWEEN TRUSSES; NAIL OSB WALL SHEATHING TO BLOCKS & VERTICALS WITH 8d @ 6" ON CENTER.
4. 2 X 4 HORIZONTAL BLOCK BETWEEN TRUSS BOTTOM CHORDS WITH (1) A35 (OR EQUAL) CONNECTING BLOCK TO TOP PLATE
5. "SIMPSON" LS50 CLIP TO CONNECT BLOCKING TO TOP PLATE (1 per truss space)
6. EXTERIOR WALL; ROOF SHEATHING MUST CONNECT VIA THIS BOX BLOCK DETAIL
7. 7/16" OSB WALL SHEATHING
8. 7/16" OSB – NAIL TO BOX BLOCK FRAME PERIMETER 8d @ 6" ON CENTER

### **THIS BLOCKING MUST OCCUR AT ALL THE FOLLOWING LOCATIONS:**

- ALL 4' BRACED PANELS (all corners & at 25 foot intervals; this will be marked on the plans)
- ANY ALTERNATE BRACED WALLS (this will be marked on the plans)
- ALL "PORTAL FRAMES" ALONG ENTIRE LENGTH OF PORTAL FRAME
- AT ANY SPECIAL BRACING AREAS, SUCH AS 3-SIDED GARAGES (sometimes referred to as "strong wall" design)